

REVISIONS			
REV	DESCRIPTION	DATE	APPROVED
1	Re draw on CAD	1/15/04	BE
2	Add plating	12/2/08	BE
3	Add note 3	6/2/09	BE

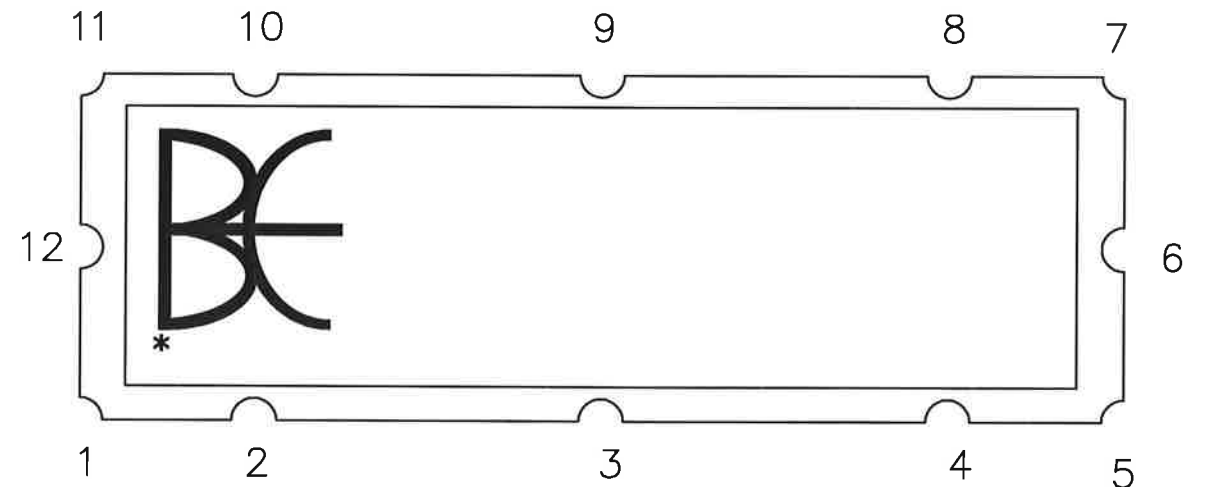
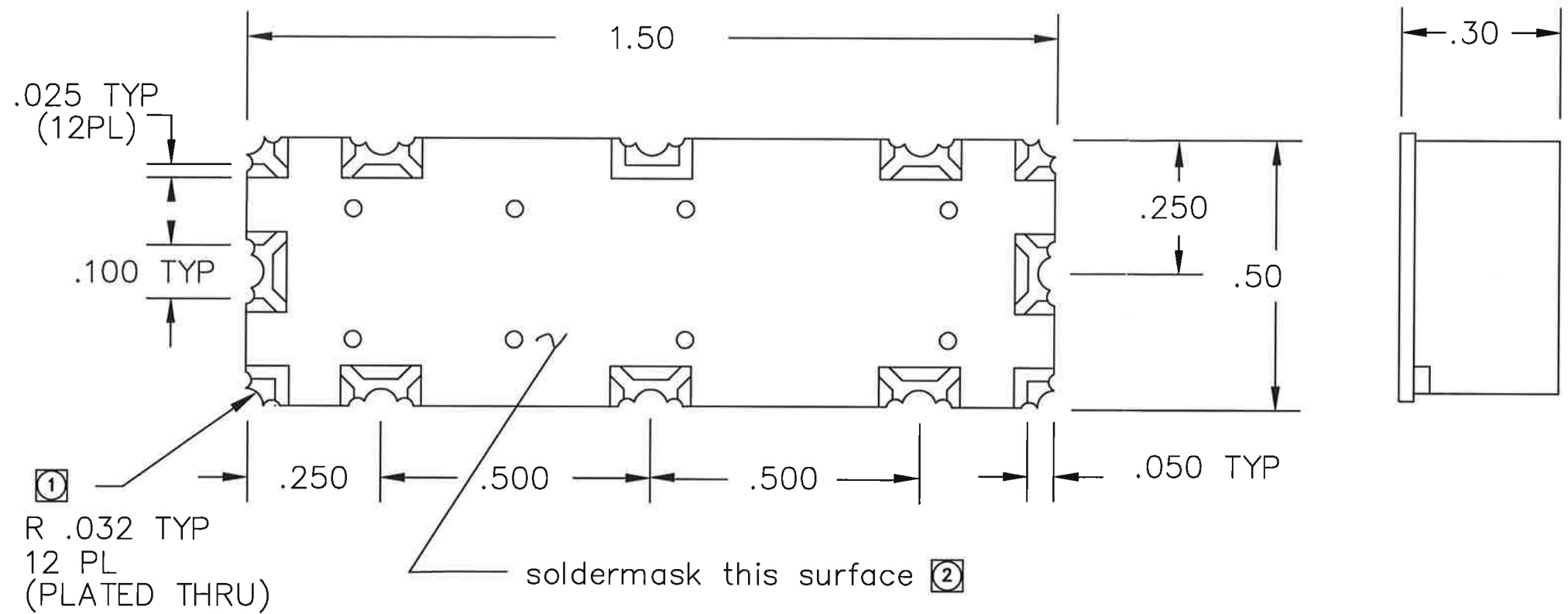

CONTACT I/O (TOP VIEW)

Contact 1, 5 is Input  
 3 Contact 9 is output  
 All others are ground

- ② Solder Mask: SR1000, LPI or equivalent.
- ① Location of plated thru holes are to be held at +/- .005.

THE INFORMATION CONTAINED IN THIS DRAWING IS THE SOLE PROPERTY OF BREE ENGINEERING. ANY REPRODUCTION IN PART OR WHOLE WITHOUT THE WRITTEN PERMISSION OF BREE ENGINEERING IS PROHIBITED.

UNLESS OTHERWISE SPECIFIED DIMENSIONS ARE IN INCHES & TOLERANCES ARE: .XXX .XX ANGLES ±.005 ±.01		CAD GENERATED DRAWING DO NOT MANUALLY UPDATE		BEE BREE ENGINEERING	
MATERIAL	PCB-FR4	DWN LN	DATE	10/19/01	
FINISH	Gold/Soldermask	CHK	RESP ENG	MFG ENG	
		QUAL ENG	Scale for REFERENCE ONLY		
SIZE	CAGE CODE	DWG NO	REV		
B	1K3H5	700068	3		
SCALE 4:1			SHEET 1 OF 1		